

# Temescal

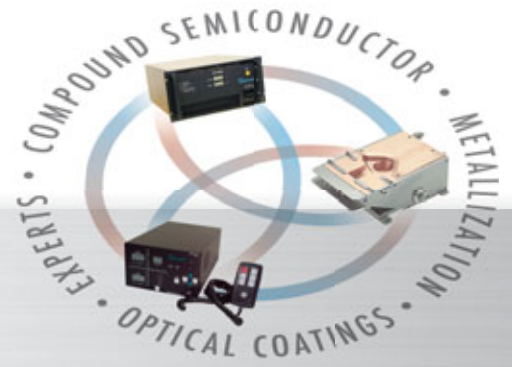

## TEMESCAL MODEL 1CK REMOVABLE COVER SUPERSOURCE

The Temescal Model 1CK SuperSource offers enhanced convenience and dependability in any application where small crucible size is desirable. The removable crucible cover exposes only the pocket in evaporation position, reducing the risk of cross-contamination. Crucible cover removal allows speedy source replenishment and makes it easy to clean the crucible and adjacent structures in situ, without risk of cross-contamination. Cover removal requires only the extraction of four screws; it is not necessary to blow the cooling water out of the source beforehand. In addition, once the water is blown out of the source, the crucible can easily be replaced, either with a clean crucible of the same pocket configuration or with a differently-configured crucible.

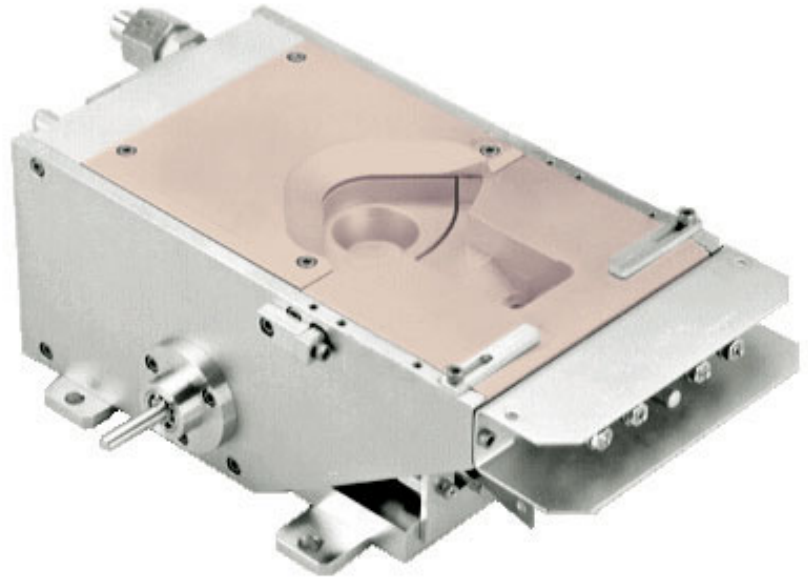

### FEATURES & BENEFITS

- Easily removable/replaceable top plate and crucible
- Side or bottom drive
- Power rating: 1-8 kW
- Crucibles available in 4 x 7-cc and 6 x 4-cc pocket configurations
- Ultra-stable magnetics eliminate the need to regauss magnetic parts following source disassembly
- Enhanced crucible cooling improves thermal stability during evaporation
- Adjustable internal and external pole-piece extensions optimize beam spot control



Via A. Volta n. 27  
20082 Binasco (Milano)  
Tel. 39 02 90093082  
Fax. 39 02 9052778  
info@gambetti.it  
www.gambetti.it  
www.plasmi.eu

# FerroTec

# TEMESCAL MODEL 1CK REMOVABLE COVER SUPERSOURCE

## Design Enhancements

The Temescal Model 1CK source offers several design enhancements that yield superior performance and serve to streamline major maintenance procedures. Extended cooling channels in the crucible direct cold water past the critical hot spot near the front edge of each pocket, improving thermal stability. In addition, internal and external pole piece extensions enable the user to optimize beam spot size and shape, regardless of the beam's position in the pocket. The Model 1CK source also provides superior magnetic stability, eliminating the need to regauss magnetic parts each time the source is disassembled.

## Options and Accessories

Temescal offers the 1CK SuperSource in side- or bottom-drive models. Standard crucibles have either four 7-cc pockets or six 4-cc pockets. Each source comes with a spare parts kit that contains machine screws, O-rings, and a quad ring. Optional accessories include Temescal's TRC-3460 turret indexer, a wide selection of crucible liners for 7-cc pockets, and a feedthrough kit. The TRC-3460 indexer features manual or automatic pocket selection, forward and reverse motion, and electronic phase adjustment. The indexer can be configured for use with any crucible configuration available for the 1CK SuperSource.

The optional crucible liners are available in a variety of materials (see ordering information on page 4). The liners reduce thermal conductivity between the evaporant pool and the crucible. They also allow particulate-free pocket replenishment and eliminate the risk of contamination when one material replaces another in a given pocket.

The optional feedthrough kit contains all the feedthroughs required to install the source. All feedthroughs are of the standard one-inch bolt-hole, O-ring-sealed type.

## SPECIFICATIONS

<b>Dimensions</b>	See illustration	<b>Sweep capability</b>	Longitudinal and lateral when operated with a beam sweep controller
<b>Weight</b>	23.5 lbs. (10.7 kg)	<b>Installation Requirements</b>	
<b>Rotation torque</b>	10 in. • lbs. (11.5 kg • cm)	<b>Input Power</b>	
<b>Max. bakeout temp.</b>	302° F (150° C)	Filament current	70 A at 12 VAC
<b>Max. power</b>	8 kW	Emission current	0–1.5 A at 4–10 kVDC (8 kW max.)
<b>Acceleration voltage</b>	4–10 kV	<b>Cooling water</b>	
<b>Operating pressure</b>		Max. temperature	68° F (20° C)
Maximum	$5 \times 10^{-4}$ torr ( $6.7 \times 10^{-4}$ mbar)	Flow rate	2.75 gpm (0.17 l/sec.)
Minimum	$1 \times 10^{-8}$ torr ( $1.33 \times 10^{-8}$ mbar)	Max. inlet pressure	100 psi (6.89 bar)
<b>Beam characteristics</b>		Min. delta pressure	50 psi (3.45 bar)
Deflection	270°	<b>Feedthroughs</b>	
Spot size/shape	From tight oval to diffuse oblong		<ul style="list-style-type: none"><li>• Two HV feedthroughs rated for 12 kV at 70 A</li><li>• One octal feedthrough rated for 110 V at 3 A per lead</li><li>• One dual-pass feedthrough with 3/8-in. (9.5-mm) OD tubes</li><li>• One rotary-motion feedthrough with 1/4-in. (6.4-mm) dia. shaft</li></ul>
<b>Evaporation rate</b>	25 kÅ of Aluminum at 10-in. (254-mm) source-to-substrate distance		

# TEMESCAL MODEL 1CK REMOVABLE COVER SUPERSOURCE

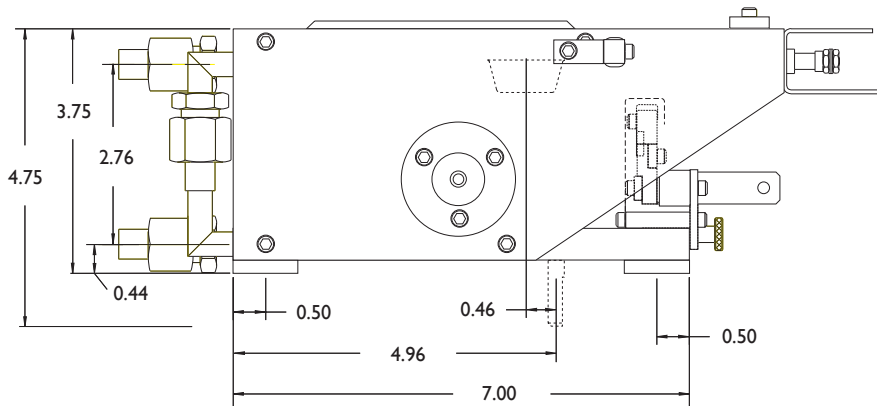
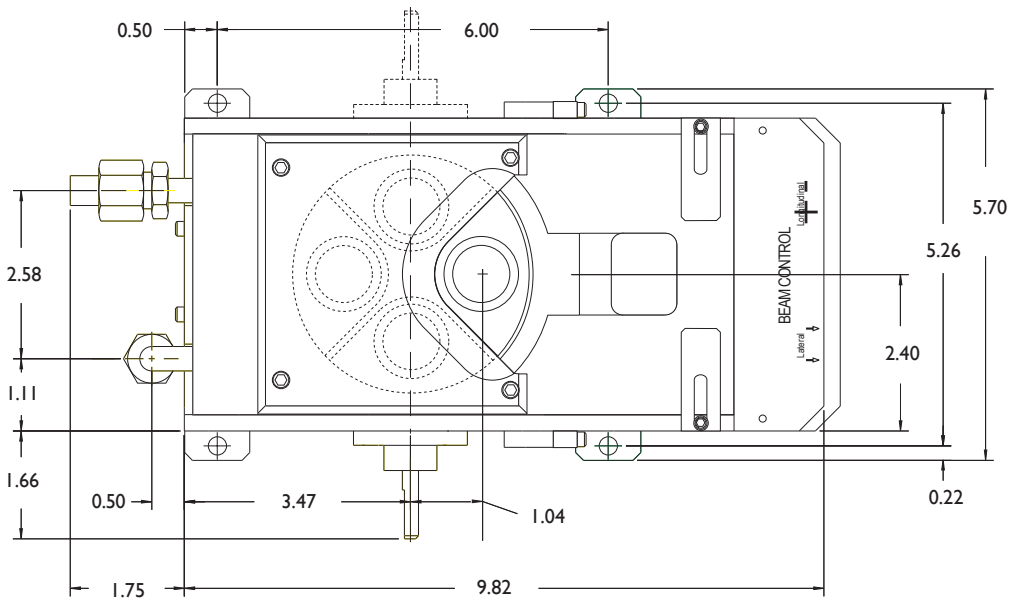
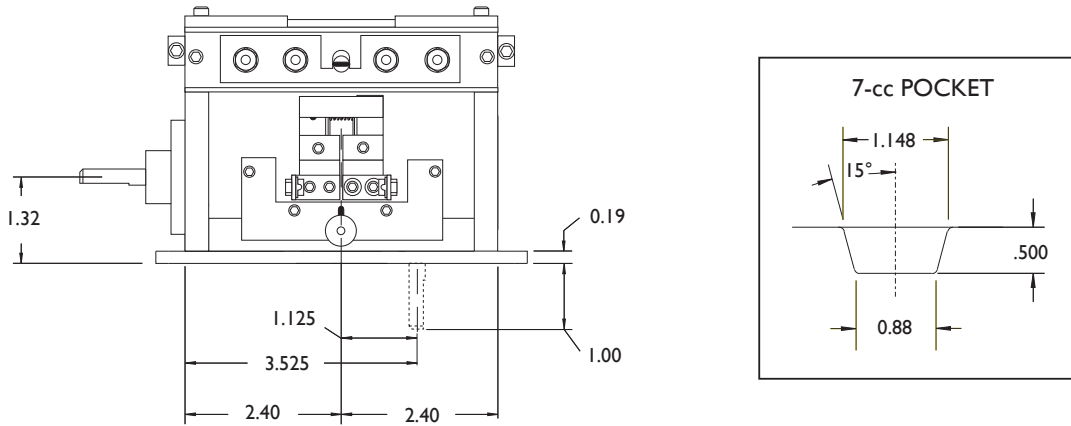

# TEMESCAL MODEL 1CK REMOVABLE COVER SUPERSOURCE

## ORDERING INFORMATION

For each source you wish to order, specify part numbers for a base unit, an emitter, and a spare parts kit. Also specify by part number which crucible(s) and crucible cover(s) you wish to order for each source.

### Complete Model 1CK Source

#### Base Unit

DESCRIPTION	PART NUMBER
Side drive base unit	0715-9134-0
Bottom drive base unit	0715-9144-0
*Each base unit includes one spare parts kit for the source (but not for the emitter assembly) and one manual.	

#### Emitter Assembly

DESCRIPTION	PART NUMBER
High-performance emitter	0916-8294-0

#### Emitter Spare Parts Kit

DESCRIPTION	PART NUMBER
Spare parts kit for high-performance emitter	0916-8300-0



#### Crucible

DESCRIPTION	PART NUMBER
4 x 7-cc pockets	0715-9284-0
6 x 4-cc pockets	0626-2834-0

#### Crucible Cover

DESCRIPTION	PART NUMBER
Cover for 4-pocket crucible	0715-9303-0
Cover for 6-pocket crucible	0626-0783-0

The Model 1CK SuperSource is covered by one or more of the following U.S. patents: 3,177,535; 3,483,417; 3,710,072

#### Optional Source Accessories

DESCRIPTION	PART NUMBER
Feedthrough kit	0503-0201-1
SS64 Programmable beam sweeper	0611-8570-0
TRC-3460 Turret source indexer	0040-9380-3

#### Optional Crucible Liners for 7-cc Pockets

DESCRIPTION	PART NUMBER
Molybdenum liner	0627-6261-1
ATJ-grade graphite liner	0627-6172-1
Poco® graphite liner	9998-9004-0
Tungsten liner, lanthanated	0627-6152-1L

Poco® is a registered trademark of Union Oil

# Temescal

[www.Temescal.net](http://www.Temescal.net)

#### AUSTRALIA

**AVT Services**  
Unit 16/35 Foundry Road  
Seven Hills, 2147, Australia  
1 800 559 988

#### BRAZIL

**Edwards Vacuum, Brazil**  
Rua Bernado Wrona 222  
02710 Sao Paulo-SP  
+55 11 3952 5000  
+55 11 3965 2766

#### CANADA

**Linde Canada Ltd.**  
5860 Chedworth Way  
Mississauga L5R 0A2  
Ontario  
800 387 4076  
905 501 1225

#### CHINA

**Micro-Power Semiconductor Ltd**  
Room 2101  
Xinghuo Science Building  
No.2 Fufeng Road, Fengtai  
District, Beijing 100070, PRC  
+86 10 88 893350/51 ext 8010  
+86 10 88 893310

#### FRANCE, SPAIN & PORTUGAL

**MTB Solutions**  
2 rue Pierre Latecoere  
ZAC de Segla  
31600 Seysses, France  
+33 5 62 87 38 20  
+33 5 62 87 38 21

#### GERMANY

**Vactec GmbH**  
Rubinsteinstrasse 47  
D-81245 Munchen  
+49 89 864 4305  
+49 89 864 4306  
+49 89 864 4809

#### INDIA

**Vacuum Techniques, Pvt. Ltd.**  
No. 36A, AGS Layout, MSR  
Nagar, Bangalore, 560 054  
+91 80 336 3482  
+91 80 360 1639

#### ISRAEL

**Edwards Vacuum, Inc. Israel**  
5 Habarzel Blvd.  
Industrial Zone  
P O Box 8621  
Qiryat Gat 82000  
+972 7 681 0633  
+972 7 681 0640

#### ITALY

Gambetti Kenologia  
Via a. Volta N. 27  
20082 Binasco (MI)  
+39 02 900 93082  
+39 02 905 2778

#### KOREA

**Zeus Co, Ltd**  
729 Jubuk-Ri,  
Yangji-Myeon, Cheoin-Gu  
Yongin-Si, Kyeonggi-Do  
449-882 Korea  
+82 31 322 6900 x280  
+82 31 322 5544 5

#### NETHERLANDS & BELGIUM

**A. De Jong**  
Toermalijnring 1000  
3316 LC Dordrecht  
Netherlands  
+31 78 655 2000  
+31 78 655 20 10

#### RUSSIAN FEDERATION

**Intech Vacuum**  
33/1 Engelsa Avenue  
408 Office  
St. Petersburg, 194156  
Russian Fed.  
+7 812 336 38 96  
+7 812 326 38 95

#### SINGAPORE

**Ellipsiz, Ltd**  
29 Woodlands Ind. Park E1  
#04-01/06 NorthTech Bldg.  
Singapore 757716  
(65) 6311 8500  
(65) 6269 2628

#### TAIWAN

**Junsun Tech Co., Ltd**  
7F, 659, Chung-Cheng Rd.  
Hsin-Chuang City  
Taipei County 242  
Taiwan ROC  
+886 2 29081350 x 11  
+886 2 29081305

#### UK & IRELAND

**Scotech**  
Netherton Road  
Lanqank, Renfrewshire  
Scotland PA14 6YG  
+44 1 475 540 689  
+44 1 475 540 206

#### UNITED STATES

**Temescal Headquarters**  
4569-C Las Positas Road  
Livermore, CA 94551  
800 522 1215 (U.S.)  
925 449 4096

© 2010 Ferrotec (USA) Corporation. All rights reserved.  
Ferrofluidic is a registered trademark of Ferrotec Corporation.

# Ferrotec