



Flow Solutions

WWW.MKSINSTITUTE.COM

P4B

MULTI-GAS/MULTI-RANGE MASS FLOW CONTROLLER FOR FAST AND ACCURATE CONTROL OF CRITICAL PROCESS GASES

The MKS, model P4B MFC, is the next generation of MKS multi-gas/multi-range MFC for critical process gas flow control. The device uses the latest in electronics and valve components enabling it to meet the most critical of process gas flow control requirements.

The performance capabilities of the P4B are quickly apparent where short process steps are required given the sub 750 millisecond control times and accuracy to within 1% of set point. This performance extends over the range of process gases, whether "light" gases such as helium or "heavy" gases like SF₆. The P4B is a true multi-range/multi-gas MFC that enables the user to have confidence in this device's capability and minimize MFC inventory requirements.

Utilization of the multi-gas/multi-range capability is made simple through the device's embedded software and standard Ethernet interface that requires no special software, only a standard web browser and a PC. Already stored on the device are critical gas parameters for most of the gases in use today by the semiconductor industry. It is a simple matter of selecting the gas and specifying the range to configure the device. Through this interface the user can also perform device monitoring diagnostics while the device is operating.

Features & Benefits

Superior Performance

- Fast response to set point reduces flow stabilization time for short process steps and process control
- Tightly controlled flow accuracy of process gas enables improved chamber process matching

Reduces Overall Costs

- Reduces MFC inventory through its multi-gas/multi-range capability
- Accurate flow control over a wide dynamic range, even when down ranged, reduces need for an additional low range MFC

Easy to Integrate and Operate

- Embedded configuration and diagnostics software that allows the user to check MFC functionality without device removal from the tool
- Uses a standard web browser; no special software required
- Easy viewing of flow rate, gas type and Full Scale flow with its bright, self orienting LED display



Performance

Full Scale Flow Ranges (N_2 equivalent)	5 - 50000 sccm (consult factory for available flow ranges)
Maximum Inlet Pressure	150 psig (can not exceed pressure differential requirement across MFC)
Normal Operating Pressure Differential (N_2 F.S.) (with atmospheric pressure at the MFC outlet)	5 to 5000 sccm; 10 to 40 psid 10000 to 20000 sccm; 15 to 40 psid 30000 to 50000 sccm; 25 to 40 psid
Proof Pressure	1000 psig
Burst Pressure	1500 psig
Control Range	2% to 100% of F.S. (range on mech.)
Typical Accuracy	$\pm 1\%$ of set point for 20 to 100% F.S. $\pm 0.2\%$ of F.S. for 2 to 20% F.S.
Repeatability	$\pm 0.3\%$ of Reading
Resolution	0.1% of Full Scale
Temperature Coefficients	
Zero	< 0.05% of F.S./ $^{\circ}C$
Span	< 0.08% of Rdg./ $^{\circ}C$
Inlet Pressure Coefficient	< 0.02% of Rdg./psi
Typical Controller Settling Time (per SEMI Guideline E-17-0600)	< 750 msec., typical above 5% F.S.
Warm-up Time (to within 0.2% of F.S. of steady state performance)	< 30 min
Operating Temperature Range (Ambient)	10 $^{\circ}C$ to 50 $^{\circ}C$
Storage Humidity	0 to 95% relative humidity, non-condensing
Storage Temperature	-20 $^{\circ}$ to 80 $^{\circ}C$ (-4 $^{\circ}$ to 149 $^{\circ}$ F)
Temperature Display	0 to 100 $^{\circ}C$
Temperature Readout Units	$^{\circ}C$
Temperature Accuracy	$\pm 2^{\circ}C$
Temperature Resolution	0.1 $^{\circ}C$

Mechanical

Fittings (compatible with)	Swagelok [®] 4 VCR [®] , 1-1/8" surface mount (C-seal, W-seal), 1/2" W-seal
Display	4 digits for value, 4 characters for unit
Leak Integrity	
External (scc/sec He)	< 1 x 10 ⁻¹⁰
Through closed valve	< 1.0% of F.S. at 25 psig inlet to atmosphere (range on mech.) (To assure no flow-through, a separate positive shut-off valve is required.)
Wetted Materials	
Standard	316L S.S. VAR (equivalent to 316 S.S. SCQ for semiconductor quality), 316 S.S., Elgiloy, KM-45
Valve Seat	PTFE (Teflon)
Surface Finish	10 μ inch average Ra
Weight	less than 3 lbs (1.4kg)

Electrical Analog I/O

Input Power Required	+15 to +24 VDC @ 350mA max
Flow Input/Output Signal	0 to 5 VDC
Output Impedance	< 1 Ω
Connector	15-pin Type "D" Male, 9 pin Type "D" Male
Compliance	CE



Specifications

Digital I/O

Digital I/O	DeviceNet™	RS-485
Input Power Required	+11 to +25 VDC per DeviceNet specification (@ <3.5 watts)	+15 to +24 VDC @ 350mA max
Connector	5 pin microconnector (DeviceNet)	9 pin Type D male
Data Rate Switch	4 positions: 125, 250, 500K (Default), PGM (programmable over the network)	3 positions: 9.6, 19.2, 38.4K (Default)
Data Rate/Network Length	Data rate (user selectable) 125 Kbps, 500 meters (1,640 feet) 250 Kbps, 250 meters (820 feet) 500 Kbps, 100 meters (328 feet)	Data rate (user selectable) 9.6 Kbps, 1200 meters (4,000 feet) 19.2 Kbps, 1200 meters (4,000 feet) 38.4 Kbps, 1200 meters (4,000 feet)
MAC ID Switches	2 switches, 10 positions; 0,0 to 6,3 are hardware ID numbers; 7,0 to 9,9 are software ID numbers; (6,4 to 6,9 are unused and, if selected will default to hardware ID number 6,3)	2 switches, 10 positions; 0,0 to 9,9. Available MAC ID's are 3,2 to 9,9.
Network Size	Up to 64 nodes	Up to 32 nodes
Network Topology	Linear (trunkline/dropline) power and signal on same network cable	Master/slave
Visual Communication Indicators	LED network status (green/red) LED module status (green/red) Scrolling LED displays (MFC Type, Flow Full Scale, Gas Type, IP address, Instance Number (1 to 31)	LED network status (green/red) LED module status (green/red) Scrolling LED displays (MFC Type, Flow Full Scale, Gas Type, IP address, Instance Number (1 to 31)
Compliance	CE	CE

Dimensional Drawing

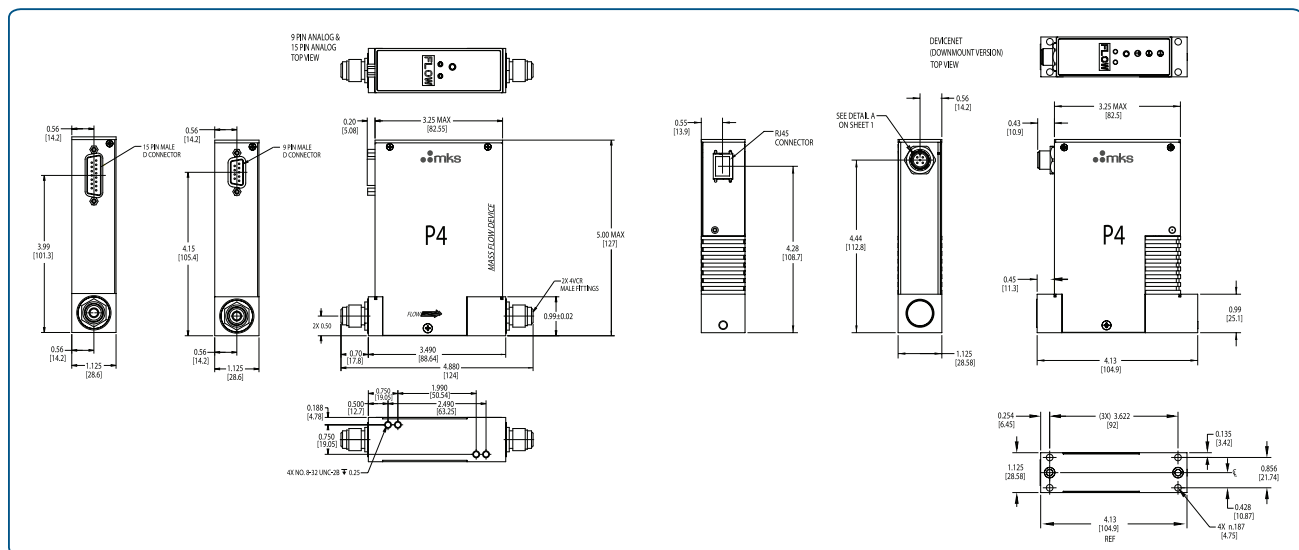

Dimensional Drawing — Analog 9 Pin D, 15-Pin D, RS-485 and DeviceNet™

Note: Unless specified, dimensions are nominal values in inches (mm referenced). Dimensions shown are for normally closed valve configuration. For normally open valve configuration dimensions, contact MKS.



Ordering Information

Ordering Code Example: P4B013502C6T030	Code	Configuration
MFC Mass Flow Controller (multigas, multi-range) P4B	P4B	P4B
Gas (Per Semi Standard E52-0703)		
For example: 013 = Nitrogen = N ₂ 029 = Ammonia = NH ₃ 110 = Sulfur Hexafluoride = SF ₆	013 029 110	013
Flow Range Full Scale*		
5 sccm 10 sccm 20 sccm 50 sccm 100 sccm 200 sccm 500 sccm 1000 sccm 2000 sccm 5000 sccm 10000 sccm 20000 sccm 30000 sccm 50000 sccm	500 101 201 501 102 202 502 103 203 503 104 204 304 504	502
Fittings (compatible with)		
Swagelok 4 VCR C-seal (1.125") W-seal (1.125")	R C H	C
Connector		
DeviceNet RS485 (uses 9 pin connector) 15 pin D (Analog I/O) 9 pin D (Analog I/O)	6 5 B A	6
Valve		
Normally Closed, Teflon®: (10 sccm - 50 slm N ₂ equivalent) Normally Open, Teflon: (10 sccm to 50 slm N ₂ equivalent) No Valve (MFM)	T P 0	T
Reserved for MKS Future Use		
Standard	0	0
Firmware		
Unless otherwise specified, MKS will ship firmware revision current to date	30	30

* The Full Scale flow rate is designated by a 3 digit number. The first two digits represent the significant digits of the Full Scale flow rate separated by a decimal point. The third digit is the exponent of the power of ten.

Example flow rate code:
254 is 2.5 x 10⁴ or 25000 sccm
153 is 1.5 x 10³ or 1500 sccm
601 is 6.0 x 10¹ or 60 sccm



MKS Instruments, Inc. Global Headquarters

2 Tech Drive, Suite 201
Andover, MA 01810
Tel: 978.645.5500
Tel: 800.227.8766 (in U.S.A.)
Web: www.mksinst.com

MKS Instruments, Inc. Flow Solutions

Six Shattuck Road
Andover, MA 01810
Tel: 978.975.2350