



# Mass Spectrometry Solutions

WWW.MKSINSTR.COM

## 300mm Resist-Torr®

### FOR HIGH PRESSURE DEGAS

It is often difficult to know when a photoresist problem is affecting the productivity of a 300mm PVD system. Even small amounts of residual resist, when introduced over a prolonged period, can reduce yields, cause particle contamination or slowly contaminate process chambers, thereby requiring premature kit changes. Major photoresist hits can be very costly, upwards of hundreds of thousands of dollars for lost wafers, especially if the tantalum/copper target becomes contaminated.

### Features & Benefits

- Fully automated process monitoring – no operator necessary
- Detection of photoresist contamination during high pressure (~8 Torr) degas, before wafers enter into 300mm PVD chambers
- Calculation of the PR Index® – a measure of photoresist contamination level in the degas chamber
  - WARN and STOP levels for photoresist contamination
  - Can stop the progress of a contaminated wafer through the tool
  - Sensitive enough to detect even small amounts of resist commonly found on product wafers
  - Increase die yield associated with reduced particle contamination
- Built in calibration standard with automatic calibration routine enables long-term data comparison and proper system operation
- Variable alarm sensitivity to match the conditions of your product in your fab or process tool
- Powerful optional data review feature to maximize ROI
  - Faster PM recovery through vacuum analysis helps minimize chamber turnaround time
  - Highlights chronic, low-level residual photoresist contamination that can cause reduced PreClean kit-life and excess particles
  - Reports of gases and PR Index for comparisons, as well as for long term trend analysis



Resist can be inadvertently introduced to PVD systems in a number of ways. Rushing Hot Lots through opens the door to skipping steps like the resist strip or even the complete etch and strip cycle. This could result in contamination throughout the process tool if the wafer is not stopped at the degas chamber. Such process flow errors can impact PVD tool performance, immediately, from a single wafer. More common, however, is the incomplete removal of resist. This can happen due to a poorly controlled end point in the ashers such as from first-wafer, cold-chamber effects, or from faults on integrated etch/strip tools.

Each of these mechanisms can leave resist contamination on wafers which eventually is seen as a loss of die or high particle densities in sputter etch process chambers. Resist contamination can be the cause of a series of factors, all of which work to reduce tool availability, increase COO, and decrease the overall yield of a process flow.

### The 300mm Resist-Torr®

The 300mm Resist-Torr consist of an optimum combination of a closed ion source quadrupole mass analyzer with fast response capillary inlet, together with advanced proprietary algorithms developed exclusively for the degas chambers on industry leading 300mm PVD cluster tools. When utilized with the powerful features of Process Eye™ and TOOLweb RGA sensor control software package, the result is completely automated operation and highly reliable photoresist detection. Unscheduled downtimes are reduced and device yields are improved.

The 300mm Resist-Torr considers many different parameters of the degas step and combines that data to provide information in the form of a meaningful number, without the need for user-interpretation. This measurement, termed the PR Index®, is a normalized measure of wafer borne photoresist contamination that can be presented in various forms to compare data over time.

The 300mm Resist-Torr can interrupt the processing of any wafer automatically, without operator intervention, if a wafer enters the vacuum system with detrimental levels of residual photoresist, as determined by the PR Index.

PR Index trace for wafer sequence run at a foundry with interspersed normal and known PR contaminated wafers; red (alarm) and yellow (warning) lines show the default control limits PR Index trace for a series of test wafers run at a 300mm PVD tool OEM. The PR hit event was much longer than the preceding normal wafers because the tool was stopped on that wafer.

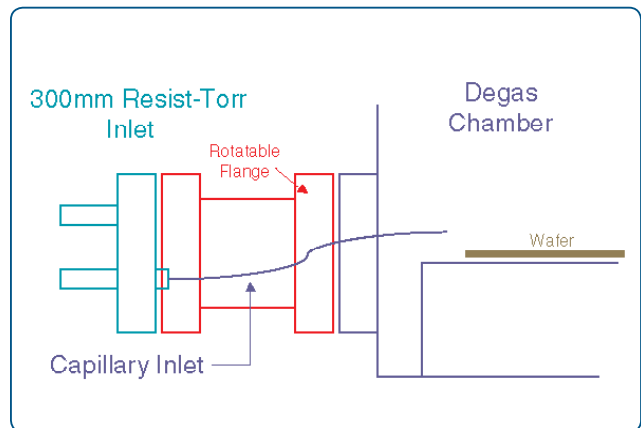

Installation Schematic

### TOOLweb® RGA

Using TOOLweb RGA sensor integration option for process tools, the 300mm ResistTorr can be used as a degas chamber sensor in a completely automated process environment. TOOLweb RGA maintains a constant monitor of tool activities with all sensor data being framed by wafer logistics before alarm models are applied. Full alarm and data reporting to the FAB host and FDC are available so real time monitoring of chamber conditions and flagging of any process excursions from ideal conditions is possible.

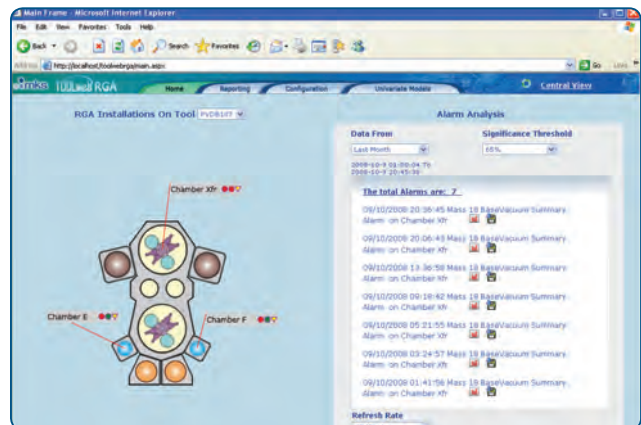

TOOLweb® RGA Screen Home page for a tool with two 300mm ResistTorr degas modules. The dashboard view presents a complete status report and automated alarm analysis on one page.



# Specifications

## Performance

Mass Range	1-200 amu
Detector System	Dual (Faraday and Secondary Electron Multiplier)
Minimum Detectable Concentration	<100ppb for all common gases except <10ppm for H <sub>2</sub>
Mass Stability	Better than ±0.1 amu over 8 hours at stable ambient temperature
Resolution	Better than 10% valley between peaks of equal height throughout the mass range

## Analyzer & Housing

Ion Source	High sensitivity, closed ion source
Filaments	Replaceable twin Thoria filaments
Analyzer Housing Base Pressure	Better than 5x10 <sup>-9</sup> Torr after bakeout
Inlet	Dual path with fast-response capillary for degas monitoring and high conductance for base vacuum. Includes heater jacket.
Mass Filter	Double filter (1" "RF only" pre-filter with 4" main filter)
Mounting Flange	2.75" Conflat® flange, SS capillary
Bakeout Temperature & Bakeout Jacket	Included for 200°C bakeout
Vacuum Hardware	60 l/s turbomolecular pump with high conductance analyzer housing, fast response capillary inlet system, automated vacuum controller (RVC) completely interlocked and integrated
Foreline Pump	Dry diaphragm standard
Calibration Hardware	Reference gas standard for automated calibration

## Control Unit/PC

Control Module Weight	1.7 kg
Power	88-264 VAC, 47/63 Hz, 600 Watts
Maximum Operating Conditions	Electronics: 10-40°C, 80% RH (non-condensing)
LED Status Indication	Interlock status, filament emission, SEM, power and communications
I/O Capability	4 analog inputs and 2 outputs (plus 1 dedicated gauge input). Optional support for a large number of both analog and digital inputs and outputs, including relay control
Other Facilities	Leak check headset socket, external filament trip socket, instrument reset
Software	Process Eye Professional fully network compatible control platform generating under 32bit or 64bit Microsoft® Windows® XP, Vista, Server 2008 or Windows 7* (*recommended)
Communications	Ethernet CAT-5e
Minimum PC Specification Required	Intel® Pentium IV® or AMD Athlon XP 1.2GHz, 1GB RAM, 120 GB hard drive, dependent upon total number of sensors on the computer and the operating system in use. Multi-sensor installation may require higher specifications. Simultaneous Multi-Sensor Process Eye Professional client/server configuration offers flexible multi-sensor operation.
RGA Controller to Vacuum System Cables	Length 33' (10 m) standard RGA. Other lengths available dependent upon process system and customer requirements
Compliance	CE

## Facilities

Power	88-264 VAC, 47/63 Hz, 600 Watts
Pneumatics	60-80 psig CDA
Weight at Tool	Approx. 24 lbs (11.0 Kg) to bolt-on process system (support stand or bracket required)
Shipping Weight	Approx. 85 lbs (38.5 Kg); can vary depending upon configuration



## Ordering Information

Please contact your local MKS office for price and availability information.

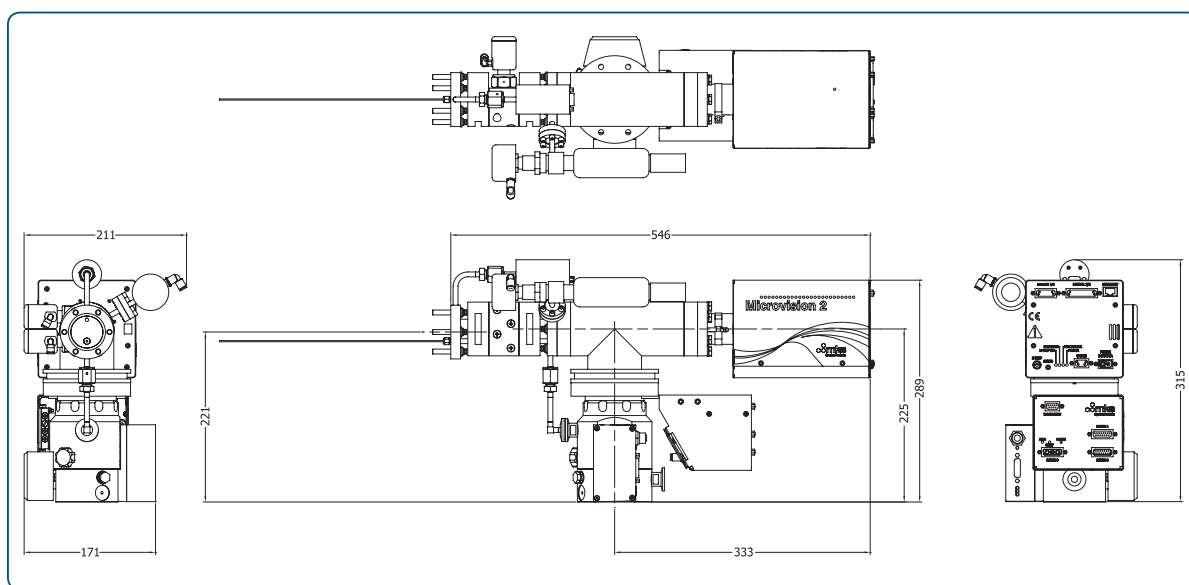

### Dimensional Drawing —

Unless otherwise specified, dimensions are nominal value in millimeters.



#### **MKS Instruments, Inc. Global Headquarters**

2 Tech Drive, Suite 201  
Andover, MA 01810  
Tel: 978.645.5500  
Tel: 800.227.8766 (in USA)  
Web: [www.mksinst.com](http://www.mksinst.com)

#### **MKS Instruments, Inc. Mass Spectrometry Solutions**

3635 Peterson Way  
Santa Clara, CA 95054  
Tel: 408.750.0300

#### **MKS Instruments, Inc. Mass Spectrometry Solutions**

Cowley Way  
Crewe, Cheshire CW1 6AG  
Tel: +44.1270.250150