



Flow

Solutions

WWW.MKSINST.COM

GE250A

MULTI-GAS/MULTI-RANGE MASS FLOW CONTROLLER FLOW RATES UP TO 250 SLM

The GE250A is a general purpose, elastomer sealed MFC well suited for a wide variety of applications requiring flow control capability from 100 slm to 250 slm FS, N₂ equivalent. The GE250A incorporates the latest in digital flow control electronics along with a well proven, patented thermal sensor and mechanical design. This MFC is available with either analog or digital I/O. The digital control electronics utilize the latest in MKS control algorithms provide fast and repeatable response to set point.

Settling times of 1 to 2 seconds and set point accuracies below 1% of set point outperform those of other typical high flow MFCs. Precise control is maintained down to 2% of the GE250A configured Full Scale flow range. The multi-gas/multi-range capability, along with tight performance specifications for accuracy, control range, and transient response allow users to minimize inventory of high flow MFC part numbers.

The multi-gas/multi-range feature (along with other custom controls) is accessed through the MFCs embedded diagnostic interface, which requires no special software or hardware to operate. A standard Ethernet cable and JAVA-enabled HTML browser, widely available, are all the tools needed. The critical gas parameters for typical high flow rate gases are already stored on the device. Configuring the device is simply a matter of selecting the gas from a drop down menu and specifying the desired full scale flow range. The diagnostic interface also allows the user to perform routine device health checks, plot flow response, and store operating data for offline analysis.

Features & Benefits

Improved Performance

- Fast response to set point change reduces flow stabilization time for short process steps, enhancing process throughput
- Tightly controlled flow accuracy of process gas enables improved process matching
- Reduced inlet pressure (pressure drop) requirement simplifies gas supply regulation from a single source

Reduces Overall Costs

- Reduces MFC inventory through its multi-gas/multi-range capability
- Accurate flow control over a wide dynamic range, even when down ranged, reduces need for an additional low range MFC

Easy to Integrate and Operate

- Device configuration and diagnostics made simple through standard Ethernet interface
- Uses a standard web browser with no special software required

Performance

Full Scale Flow Ranges (<i>N₂ equivalent</i>)	100 to 250 slm
Maximum Inlet Pressure	150 psig (cannot exceed pressure differential requirement across MFC)
Normal Operating Pressure Differential (with atmospheric pressure at the MFC outlet)	30 to 55 psid (dependent on fitting type)
Burst Pressure	1500 psig
Control Range	2% to 100% of F.S. (range on mech.)
Typical Accuracy	± 1% of set point for > 20% to 100% F.S. ± 0.25% of F.S. for 5% to 20% F.S.
Repeatability	± 0.5% of Reading
Resolution	0.1% of Reading
Temperature Coefficients	
Zero	< 0.05% of F.S./°C
Span	< 0.08% of Rdg./°C
Inlet Pressure Coefficient	< 0.03% of Rdg./psi or less
Typical Controller Settling Time	1 to 2 seconds typical above 10% F.S. @ 50 psi
Warm-up Time	one (1) hour
Operating Temperature Range (<i>Ambient</i>)	10°C to 50°C
Storage Humidity	0 to 95% relative humidity, non-condensing
Storage Temperature	-20° to 65°C (-4° to 149° F)

Mechanical

Fittings (<i>compatible with</i>)	8 VCO® male, ½" NPT female, ½" Compression, 8 VCR® male, 12 mm Swagelok, ¾" Swagelok, W-seal, ½" Compression Long, 8 VCR Long, 8 VCO Male Long
Leak Integrity	
External (scc/sec He)	< 1 x 10 ⁻⁹
Through closed valve	< 1.0% F.S. at 40 psia to vac (<500 mTorr) (To assure no flow-through, a separate positive shut-off valve is required.)
Wetted Materials	
Standard	316 S.S., 17-7 S.S., Elgiloy®, 430FR
Seal Options	Viton®, Buna-N, Neoprene®, EPDM
Surface Finish	16 µinch average Ra
Weight	Less than 4.5 lbs. (2.05 kg)

Electrical Analog I/O

Input Power Required	+15 to +24 VDC @ (< 4 watts)
Flow Input/Output Signal	
Voltage (0 to 5 VDC)	15-pin Type "D" male
Current (4 to 20 mA)	15-pin Type "D" male
Compliance	CE

Digital I/O

	DeviceNet™	Profibus®
Input Power Required	+11 to +25 VDC per (< 4 watts)	+15 to +24 VDC (< 4 watts)
Connector	5 pin micro connector (power and comm.)	9 pin Type D male (power) 9 pin Type D female (comm.)
Data Rate Switch/Selection	4 positions: 125, 250, 500K, (Default) (programmable over network)	No switch Set data rate via Profibus
Comm. Rate(s)	125 Kbps, 250 Kbps, 500 Kbps	9.6 Kbps to 12 Mbps
MAC ID Switches/Addresses	2 switches, 10 positions; 0,0 to 6,3 1 to 254	2 switches, 10 positions
Network Size	Up to 64 nodes	Up to 99 nodes
Visual Indicators	LED Network (green/red) LED Module (green/red)	LED Comm (green/red) LED Error (green/red)
Compliance	CE	CE



Dimensional Drawing

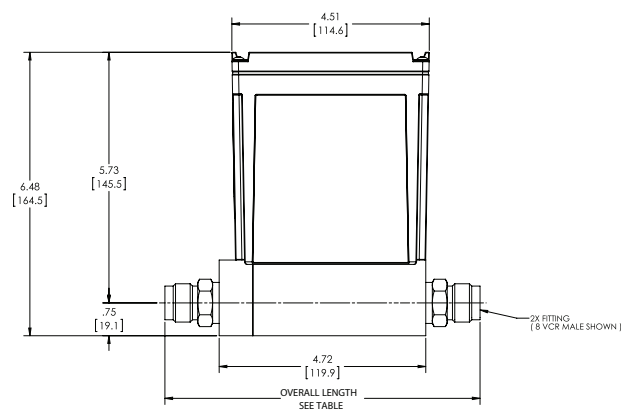
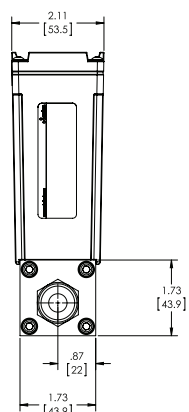
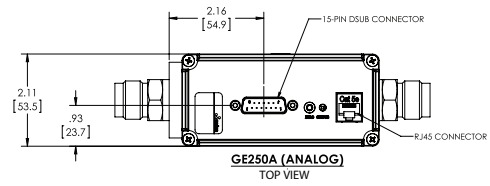

Fitting Code	Fitting Name	Overall Length
D	8 VCO Male	6.78"
M	½" NPT Female	7.36"
S	½" Compression	6.35"
T	8 VCR Male	7.20"
H	9/16-18 UNF	6.22"
W	½" Compression Long	8.25"
L	8 VCR Male Long	8.63"
J	¾" Compression	6.34"
F	12mm Compression	6.34"
Q	8 VCO Male Long	8.31"

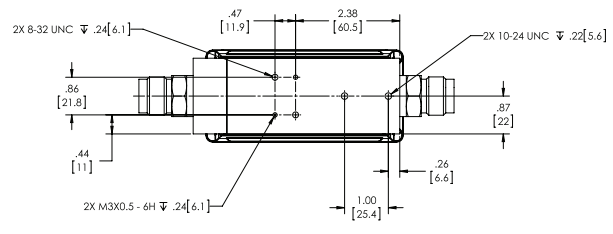

Dimensional Drawing

Note: Unless specified, dimensions are nominal values in inches (mm referenced).
 *(See manual for additional I/O and fitting types)



Ordering Information

Ordering Code Example: GE250A013255T8E0020	Code	Configuration
MFC High Flow Mass Flow Controller (multi-gas, multi-range)	GE250A	GE250A
Gas*		
For example: 001 = Helium = He 004 = Argon = Ar 007 = Hydrogen = H ₂ 013 = Nitrogen = N ₂	001 004 007 013	013
Flow Range Full Scale**		
250 slm (250,000 sccm)	255	255
Fittings (compatible with)		
12 mm Swagelok 3/8" Swagelok 1/2" tube compression 1/2" Compression Long 1/2" NPT female 8 VCR Male 8 VCO Male 8 VCR Male Long 8 VCO Male Long W-Seal	F J S W M T D L Q H	T
Connector (Power & Control I/O)		
EtherCAT® DeviceNet RS485 (uses 9 pin connector) Profibus Profinet 15 pin D (Analog 0 to 5 VDC I/O) 15 pin D (4 to 20 mA I/O)	8 6 5 4 9 B H	8
Seal Materials		
EPDM Viton Buna-N Neoprene	E V B N	E
Valve Type		
Normally closed Meter	0 3	0
Reserved for MKS Future Use		
Standard	0	0
Firmware		
Unless otherwise specified, MKS will ship firmware revision current to date	20	20

* For gases not listed in the standard products gas table, please contact the MKS applications department for assistance.

Gas Table			
Gas Name*	Semi Gas Code	Gas Formula	Min - Max FS (slm)
Helium	001	He	140 to 350
Argon	004	Ar	140 to 250
Hydrogen	007	H ₂	100 to 250
Air	008	Air	100 to 250
Nitrogen	013	N ₂	100 to 250

** The Full Scale flow rate is designated by a 3 digit number. The first two digits represent the significant digits of the Full Scale flow rate separated by a decimal point. The third digit is the exponent of the power of ten.

Example flow rate code: 255 is 2.5 x 10⁵ sccm or 250 slm 105 is 1.0 x 10⁵ sccm or 100 slm



MKS Instruments, Inc. Global Headquarters

2 Tech Drive, Suite 201
Andover, MA 01810
Tel: 978.645.5500
Tel: 800.227.8766 (in U.S.A.)
Web: www.mksinst.com

MKS Instruments, Inc. Flow Solutions

Six Shattuck Road
Andover, MA 01810
Tel: 978.975.2350