



πMFC – Low Pressure

MASS FLOW CONTROLLER FOR ION IMPLANT APPLICATIONS

The PFC-20, Low Pressure πMFC mass flow controller provides maximum utilization of Safe Delivery Source gases. Implementation of the Low Pressure πMFC increases tool uptime by reducing the frequency of source gas cylinder changes. It offers accurate and precise control of low gas flows over a wide pressure range with source gas delivery pressure as low as 4 Torr.

This πMFC is the latest in MKS products designed specifically for SDS and VAC® source gases serving the ion implantation industry. The patented valve and sensor designs offer exceptional zero stability and accuracy for all flow conditions while maintaining the ability to rapidly achieve set point and repeatably control the gas flow. Standard-sized MFC footprint and control I/O are compatible with existing gas lines for easy integration and operation.

Features & Benefits

- Maximizes SDS source gas utilization reducing bottle changes resulting in higher tool uptime and lower cost-of-ownership
- Repeatedly controls low gas flows allowing for reduced gas consumption using parameters optimized for implanter source applications
- Digital control loop provides rapid response to set point minimizing process cycle time
- Increases tool uptime through reduction of “No Problem Found”: MFC replacements
 - Included embedded diagnostics and software allowing users to check MFC functionality without removing the MFC
 - E-diagnostics through embedded Ethernet interface allows monitoring performance parameters during operation
- Direct form-fit-function replacement for most common MFCs
- Reduces inventory costs through multi-gas, multi-range capability
- Straightforward configuration and diagnostics through Ethernet interface
 - Uses standard web browser – no special software required
 - Includes remote PC application
- Bright rotatable LED display provides easy viewing of flow rate, gas type, full scale flow range, temperature and Ethernet address

Protected under one or more of the following U.S. patents: No. 6,668,641, No. 6,668,642, No. 6,779,394, No. 6,868,862, No. 6,810,308, No. 7,004,191 or International Patents and Patents pending.



Most gases used in the semiconductor industry are supplied at a constant pressure, typically above atmosphere, and are delivered to a process at or below atmosphere. Ion implant gases are now mostly supplied at sub-atmospheric pressure using SDS or VAC source gas technology.

These SDS gases are supplied at a sub-atmospheric pressure that decreases as the gas is consumed. This is a critical difference for the mass flow controller, as inlet pressure, was typically constant. Changing inlet pressure can impact an MFC's capability to both meter and control flow accurately, as well as achieve set-point within an allowable time. The wider the range of inlet pressure that an MFC can control and meet performance criteria is critical to SDS gas utilization and tool uptime.

The π MFC-LP was specifically designed for SDS source gases and similar applications. It controls rapidly and accurately from initial SDS pressures of 650 Torr down to pressures well below 10 Torr at the MFC. The digital control electronics have been tuned to provide typical response times of less than 2 seconds. With its ability to accurately meter and control gas flow over this wide pressure range, the SDS source utilization is maximized resulting in fewer bottle changeouts, increased up-time and ultimately lower cost of ownership. See Figure 1 for typical SDS gas utilization as a function of pressure.

The π MFC multi-gas feature allows the user to configure an MFC off-the-shelf for its intended gas further lowering costs through reduced inventory requirements. This feature is enabled through a web browser utility accessed through the device's Ethernet port. The configuration utility uses a standard web browser – no special software is required.

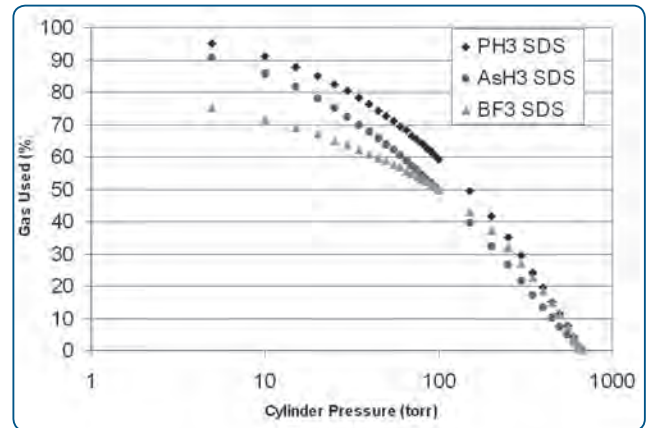
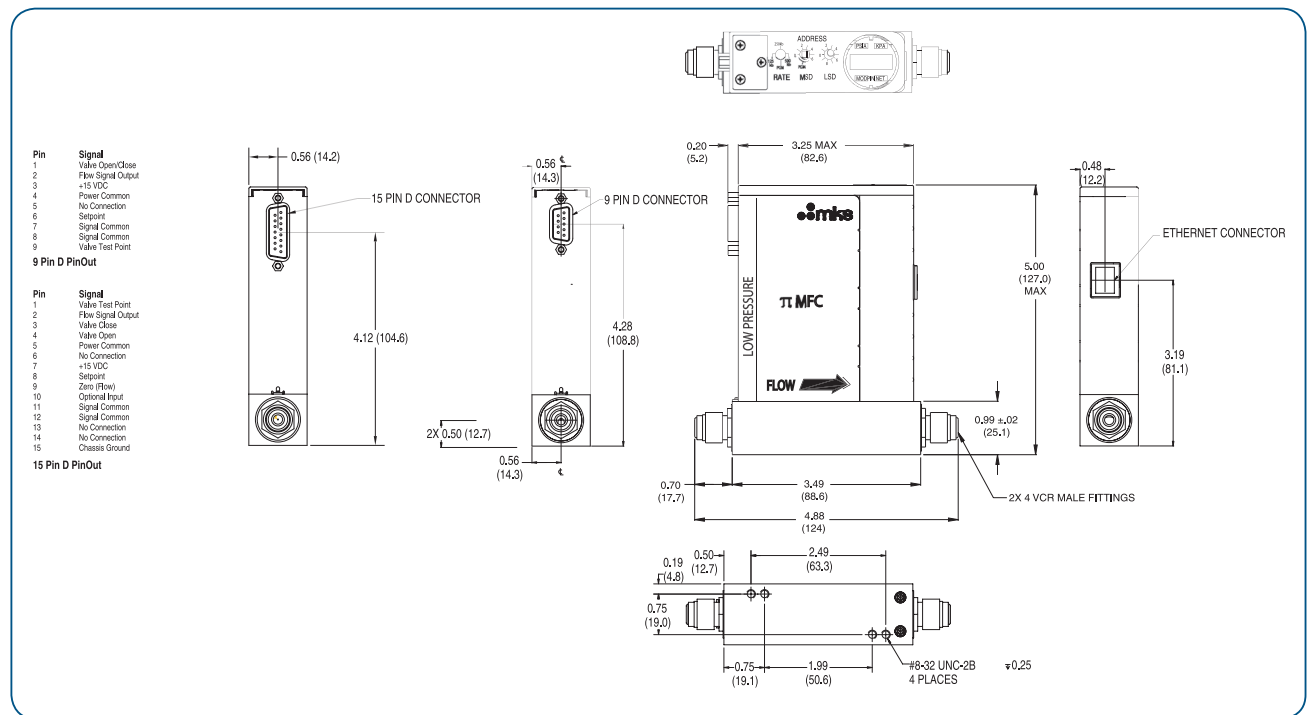

Figure 1 — SDS Gas Use Rate Efficiency



Dimensional Drawing and PinOuts—Swagelok® 4 VCR® Version with Analog 9 Pin D

Note: Unless otherwise specified, dimensions are nominal values in inches (mm referenced).



Specifications

Performance

Full Scale Ranges (N ₂ equivalent)	2 – 20 sccm
Inlet Pressure Range	4 – 1200 Torr (with vacuum at the outlet)
Normal Operating Pressure Differential (N ₂ equivalent)	<10 Torr at F.S. flow (with vacuum at the outlet)
Maximum Purge Pressure	150 psig
Burst Pressure	1500 psig
Control Range	2 to 100% of F.S.
Typical Accuracy	±1% of set point for >10 to 100% F.S. and ±0.2% of F.S. for 2 to 10% of F.S. at inlet pressures >20 Torr
Repeatability	0.2% of F.S.
Resolution	0.1% of Reading
Temperature Coefficients	
Zero	±0.08% of F.S./°C
Span	±0.08% of Rdg/°C
Controller Settling Time (per Semi Guideline E17-0600)	<2 sec. typical above 10% of F.S. at inlet pressures >10 Torr
Warm-up Time (to within 0.2% of F.S. of steady state performance)	<30 min.
Normal Operating Temperature	10 to 50°C
Storage Humidity	0 to 95% Relative Humidity, no condensing
Storage Temperature	-20 to 65°C
Temperature Display	0 to 100°C
Temperature Readout Units	°C
Temperature Accuracy	±2°C
Temperature Resolution	0.1°C

Mechanical

Fittings	Swagelok® 4 VCR®
Display	4 digits for value, 4 characters for unit
Leak Integrity	
External (scc/sec He)	<1x10 ⁻¹⁰
Through Closed Valve	<1.0% of FS at 25 psig to atmosphere
Wetted Materials	
Standard	316 S.S. VAR (equivalent to 316 S.S. SCQ for semiconductor quality), 316 S.S., Elgiloy, KM-45, NiTi
Surface Finish	5 microinch average Ra
Weight	Less than 2 lbs. (0.9 kg)

Electrical

Connectors	
Analog (power & I/O)	9 pin D male or 15 pin D male
Diagnostics	Ethernet
Input Voltage	15-24 VDC ±5%VDC @ 350mA peak, 250 mA steady state
Set Point Command Signal	0 to 5 VDC
Output Signal	0 to 5 VDC



Ordering Information

Ordering Code Example: P2A035500RAT2	Code	Configuration
πMFC Mass-Flo Controller (multi-gas, multi-range)	P2A	P2A
Gas		
013 = Nitrogen = N ₂	013	035
096 = Arsenic Pentafluoride = AsF ₅	096	
035 = Arsine = AsH ₃	035	
048 = Boron Trifluoride = BF ₃	048	
099 = Germanium Tetrafluoride = GeF ₄	099	
023 = Hydrogen Selenide = H ₂ Se	023	
031 = Phosphine = PH ₃	031	
062 = Phosphorus Trifluoride = PF ₃	062	
088 = Silicon Tetrafluoride = SiF ₄	088	
<i>Based on 100% gas concentration, for other gases or mixtures, consult factory.</i>		
Flow Range Full Scale*		
2 sccm	consult factory	500
5 sccm	500	
10 sccm	101	
20 sccm	201	
Fittings		
Swagelok 4 VCR male	R	R
Connector		
9 pin D	A	A
15 pin D	B	
Valve		
Normally Closed, Teflon®	T	T
Flow Orientation		
Vertical Flow	1	2
Horizontal Flow	2	

* The Full Scale flow rate is designated by a three digit number. The first two digits represent the significant digits of the Full Scale flow rate separated by a decimal point. The third digit is the exponent of the power of ten.

Example flow rate code:
500 is 5.0 x 10⁰ or 5 sccm
151 is 1.5 x 10¹ or 15 sccm



MKS Instruments, Inc. Global Headquarters

2 Tech Drive, Suite 201
Andover, MA 01810
Tel: 978.645.5500
Tel: 800.227.8766 (in U.S.A.)
Web: www.mksinst.com

MKS Instruments, Inc. Flow Solutions

Six Shattuck Road
Andover, MA 01810
Tel: 978.975.2350